

# CROWN

PIPE & FITTINGS





# APPROVAL & STANDARTS

- UPC Listed through IAPMO R&T laboratory.
- Certified to conform to ASTM A888-Standard Specification for Hubless Cast Iron Soil Pipe and Fittings for Sanitary and Storm Drain, Waste, and Vent Piping Applications through IAPMO R&T laboratory.
- Certified to conform to CISPI 301- Standard Specification for Hubless Cast Iron Soil Pipe and Fittings for Sanitary and Storm Drain, Waste and Vent Piping Applications through IAPMO R&T laboratory.

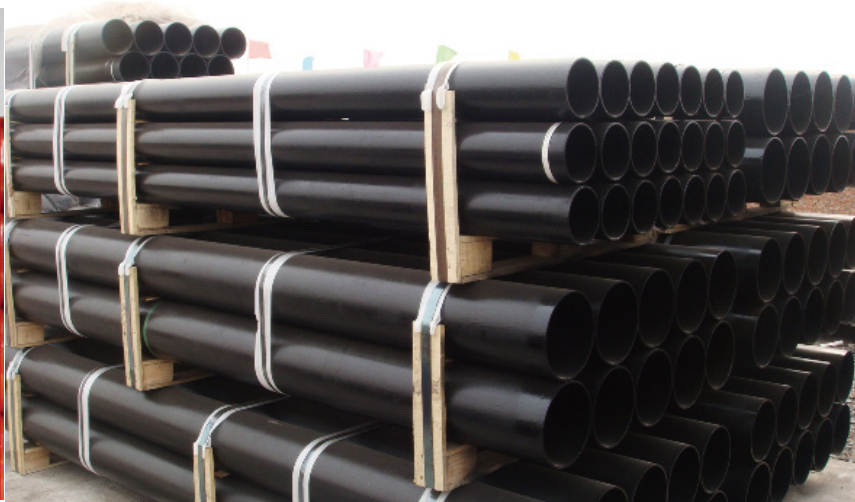

# ASTM A888 C.I. HUBLESS PIPES

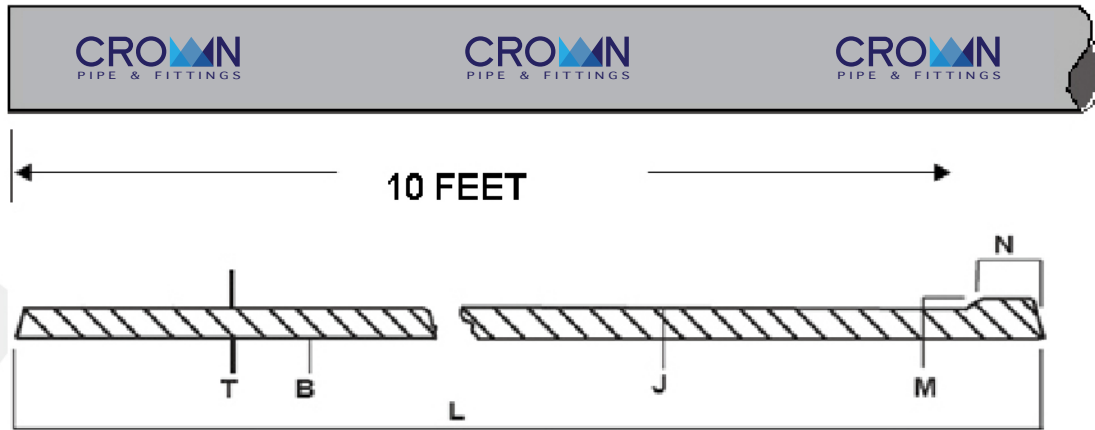

## HUBLESS PIPE (Corresponds to CISPI 301)

| ASA<br>CODE<br>NO. | SIZE | B      |            | J      |                       | T    |      | L $\pm$ 13 | APPROX WT<br>EA. (KG) | PALLET<br>QUAN. (PC) |
|--------------------|------|--------|------------|--------|-----------------------|------|------|------------|-----------------------|----------------------|
|                    |      | Nor.   | Tol.       | Nor.   | Tol.                  | Nor. | Min. |            |                       |                      |
| 0156               | 1.5  | 38.10  | $\pm 2.29$ | 48.26  | $\pm 1.52$            | 4.06 | 3.3  | 3048       | 13                    | 60                   |
| 0158               | 2    | 49.80  | $\pm 2.29$ | 59.69  | $\pm 2.29$            | 4.06 | 3.3  | 3048       | 16                    | 64                   |
| 0160               | 3    | 75.20  | $\pm 2.29$ | 85.09  | $\pm 2.29$            | 4.06 | 3.3  | 3048       | 23                    | 48                   |
| 0162               | 4    | 100.08 | $\pm 2.29$ | 111.25 | $\pm 2.29$<br>$-1.27$ | 4.83 | 3.81 | 3048       | 34                    | 30                   |
| 0164               | 5    | 125.48 | $\pm 2.29$ | 134.62 | $\pm 2.29$<br>$-1.27$ | 4.83 | 3.81 | 3048       | 42                    | 21                   |
| 0168               | 6    | 150.88 | $\pm 2.29$ | 160.02 | $\pm 2.29$<br>$-1.27$ | 4.83 | 3.81 | 3048       | 49                    | 18                   |
| 0170               | 8    | 201.68 | $\pm 3.3$  | 212.85 | $\pm 3.3$<br>$-2.29$  | 5.84 | 4.32 | 3048       | 80                    | 10                   |
| 0171               | 10   | 254.00 | $\pm 3.3$  | 268.22 | $\pm 2.29$            | 7.11 | 5.59 | 3048       | 127                   | 8                    |
| 0172               | 12   | 303.28 | $\pm 3.3$  | 317.5  | $\pm 3.3$             | 7.11 | 5.59 | 3048       | 140                   | 6                    |
| 0173               | 15   | 383.79 | $\pm 3.3$  | 402.08 | $\pm 3.3$             | 9.14 | 7.62 | 3048       | 240                   | 3                    |

## 1/4 BEND (Corresponds to table 5 of CISPI 301)

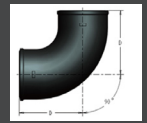

| ASA CODE NO. | SIZE | D±1/8(3.2)  | APPROX WT EA. (KG) |
|--------------|------|-------------|--------------------|
| 0188         | 1.5  | 4 1/4 (108) | 0.86               |
| 0190         | 2    | 4 1/2 (114) | 1.10               |
| 0192         | 3    | 5 (127)     | 1.80               |
| 0194         | 4    | 5 1/2 (140) | 2.70               |
| 0196         | 5    | 6 1/2 (165) | 4.75               |
| 0198         | 6    | 7 (178)     | 7.00               |
| 0200         | 8    | 8 1/2 (216) | 12.40              |

## 1/6 BEND (Corresponds to table 20 of CISPI 301)

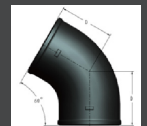

| ASA CODE NO. | SIZE | D±1/8(3.2)   | APPROX WT EA. (KG) |
|--------------|------|--------------|--------------------|
| 0570         | 2    | 3 1/4 (83)   | 0.90               |
| 0572         | 3    | 3 1/2 (89)   | 1.35               |
| 0574         | 4    | 3 13/16 (97) | 2.30               |
| 0688         | 8    | 3 3/4 (95)   | 5.6                |

## 1/8 BEND (Corresponds to table 21 of CISPI 301)

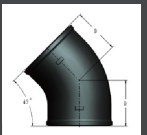

| ASA CODE NO. | SIZE  | D±1/8(3.2)    | APPROX WT EA. (KG) |
|--------------|-------|---------------|--------------------|
| 0604         | 1 1/2 | 2 5/8 (67)    | 0.65               |
| 0606         | 2     | 2 3/4 (70)    | 0.75               |
| 0608         | 3     | 3 (76)        | 1.20               |
| 0610         | 4     | 3 1/8 (79)    | 1.95               |
| 0612         | 5     | 3 7/8 (98)    | 3.00               |
| 0614         | 6     | 4 1/16 (103)  | 4.15               |
| 0616         | 8     | 5 (127)       | 7.50               |
| 0617         | 10    | 5 15/16 (151) | 13.20              |

## TAPPED ADAPTERS (Corresponds to table 65 of CISPI 301)



| ASA CODE NO. | SIZE | F          | APPROX WT EA. (KG) |
|--------------|------|------------|--------------------|
| 2244         | 2    | 2 5/8 (67) | 0.71               |

## SANITARY TEE BRANCH

(Corresponds to table 24 of CISPI 301)



| ASA CODE NO. | SIZE      | D           | E ±1/8(3.2)  | F ±1/8(3.2)   | APPROX WTEA. [KG] |
|--------------|-----------|-------------|--------------|---------------|-------------------|
| 0806         | 1 1/2     | 41/4 (108)  | 41/4 (108)   | 61/2 (165)    | 1.05              |
| 0808         | 2 X 1 1/2 | 41/4 (108)  | 41/2 (114)   | 65/8 (168)    | 1.25              |
| 0810         | 2         | 41/2 (114)  | 41/2 (114)   | 67/8 (175)    | 1.32              |
| 0812         | 3 X 1 1/2 | 41/4 (108)  | 5 (127)      | 61/2 (165)    | 1.35              |
| 0814         | 3 X 2     | 41/2 (114)  | 5 (127)      | 67/8 (175)    | 1.82              |
| 0816         | 3         | 5 (127)     | 5 (127)      | 8 (203)       | 2.10              |
| 0818         | 4 X 2     | 41/2 (114)  | 5 1/2 (140)  | 67/8 (175)    | 2.75              |
| 0820         | 4 X 3     | 5 (127)     | 5 1/2 (140)  | 8 (203)       | 3.25              |
| 0822         | 4         | 5 1/2 (140) | 5 1/2 (140)  | 9 1/8 (232)   | 3.60              |
| 0826         | 5 X 3     | 5 1/2 (140) | 6 (152)      | 9 5/16 (237)  | 5.75              |
| 0830         | 5         | 6 1/2 (165) | 6 1/2 (165)  | 11 7/16 (291) | 7.05              |
| 0836         | 6         | 7 (178)     | 12 1/2 (318) | 12 1/2 (318)  | 8.10              |
| 0832         | 6 X 2     | 5 (127)     | 6 1/2 (165)  | 8 3/16 (208)  | 5.65              |
| 0838         | 6 X 3     | 5 1/2 (140) | 6 1/2 (165)  | 9 3/16 (233)  | 6.5               |
| 0834         | 6 X 4     | 6 (152)     | 6 1/2 (165)  | 10 1/16 (256) | 7                 |
| 0848         | 8 X 3     | 6 (152)     | 7 1/2 (190)  | 10 3/8 (264)  | 10.5              |
| 0846         | 8 X 4     | 6 1/2 (165) | 7 1/2 (190)  | 11 1/2 (292)  | 11.05             |
| 0842         | 8 X 6     | 7 1/2 (191) | 8 (203)      | 13 1/2 (343)  | 12.5              |
| 0840         | 8 X 8     | 8 1/2 (216) | 8 1/2 (216)  | 15 1/2 (395)  | 16.18             |

## SANITARY TAPED TEE

(Corresponds to table 32 of CISPI 301)

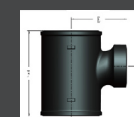

| ASA CODE NO. | SIZE      | D          | E ±1/8(3.2)  | F ±1/8(3.2)   | APPROX WTEA. [KG] |
|--------------|-----------|------------|--------------|---------------|-------------------|
| 1214         | 2 X 1 1/2 | 3 1/4 (83) | 2 13/16 (71) | 5 11/16 (144) | 1.18              |
| 1216         | 2         | 3 3/4 (95) | 3 1/16 (78)  | 6 3/8 (162)   | 1.45              |
| 1222         | 3 X 2     | 3 3/4 (95) | 3 9/16 (90)  | 6 3/8 (162)   | 1.80              |

## DOUBLE WYE

(Corresponds to table 42 of CISPI 301)

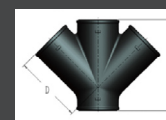

| ASA CODE NO. | SIZE  | D ±1/8(3.2)  | F ±1/8(3.2) | APPROX WT EA. [KG] |
|--------------|-------|--------------|-------------|--------------------|
| 1544         | 4 X 2 | 6 (152)      | 6 5/8 (168) | 2.95               |
| 1548         | 4     | 7 1/16 (179) | 9 1/2 (241) | 5.00               |

## WYE

(Corresponds to table 39 of CISPI 301)

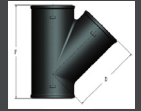

| ASA CODE NO. | SIZE    | D ±1/8(3.2)    | F ±1/8(3.2)    | APPROX WT EA. (KG) |
|--------------|---------|----------------|----------------|--------------------|
| 1314         | 2       | 45/8 (117)     | 65/8 (168)     | 1.18               |
| 1315         | 3 x 1.5 | 45/8 (117)     | 65/8 (168)     | 1.65               |
| 1316         | 3 x 2   | 55/16 (135)    | 65/8 (168)     | 1.65               |
| 1318         | 3       | 53/4 (146)     | 8 (203)        | 2.20               |
| 1320         | 4 X 2   | 6 (152)        | 65/8 (168)     | 2.50               |
| 1322         | 4 X 3   | 61/2 (165)     | 8 (203)        | 3.25               |
| 1324         | 4       | 71/16 (179)    | 91/2 (241)     | 4.00               |
| 1334         | 6 X 2   | 81/4 (210)     | 85/16 (211)    | 4.95               |
| 1336         | 6 X 3   | 83/4 (222)     | 93/4 (248)     | 5.65               |
| 1338         | 6 X 4   | 91/4 (235)     | 113/16 (284)   | 7.25               |
| 1342         | 6       | 103/4 (273)    | 141/16 (357)   | 10.10              |
| 1346         | 8 x 3   | 9 13/16 (249)  | 9 15/16 (252)  | 9.5                |
| 1348         | 8 X 4   | 103/8 (264)    | 117/16 (291)   | 9.90               |
| 1350         | 8 X 5   | 11 3/8 (289)   | 12 13/16 (252) | 12.54              |
| 1354         | 8       | 133/8 (340)    | 171/8 (435)    | 19.50              |
| 1357         | 10 X 4  | 11 11/16 (297) | 125/8 (321)    | 15.50              |
| 1359         | 10 X 6  | 131/8 (333)    | 157/16 (392)   | 19.50              |
| 1360         | 10 X 8  | 1411/16 (373)  | 183/8 (467)    | 25.90              |
| 1361         | 10      | 161/2 (419)    | 211/2 (546)    | 42.20              |

## UPRIGHT WYE

(Corresponds to table 45 of CISPI 301)

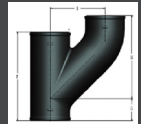

| ASA CODE NO. | SIZE  | E          | F ±1/8(3.2) | G           | H           | APPROX WT EA. (KG) |
|--------------|-------|------------|-------------|-------------|-------------|--------------------|
| 1646         | 2     | 51/2 (140) | 7 (178)     | 2 (51)      | 81/4 (210)  | 2.04               |
| 1650         | 3     | 51/2 (140) | 83/8 (86)   | 23/16 (56)  | 87/16 (214) | 3.58               |
| 1652         | 4 X 2 | 51/2 (140) | 7 (178)     | 1 (25)      | 81/4 (210)  | 3.55               |
| 1654         | 4 X 3 | 51/2 (140) | 83/8 (86)   | 111/16 (43) | 87/16 (214) | 4.25               |
| 1656         | 4     | 6 (152)    | 93/4 (248)  | 27/16 (62)  | 91/8 (232)  | 5.90               |

## COMBINATION WHY AND 1/8 BEND, DOUBLE

(Corresponds to table 50 of CISPI 301)

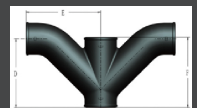

| ASA CODE NO. | SIZE | D          | E ±1/8(3.2) | F ±1/8(3.2) | APPROX WT EA. (KG) |
|--------------|------|------------|-------------|-------------|--------------------|
| 1802         | 2    | 53/8 (137) | 61/8 (156)  | 65/8 (168)  | 2.82               |

## COMBINATION WHY AND 1/8 BEND

(Corresponds to table 47 of CISPI 301)

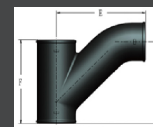

| ASA CODE NO. | SIZE  | D            | E ±1/8(3.2)  | F ±1/8(3.2)   | APPROX WTEA. [KG] |
|--------------|-------|--------------|--------------|---------------|-------------------|
| 1698         | 2     | 53/8 (137)   | 61/8 (156)   | 65/8 (168)    | 1.65              |
| 1700         | 3 X 2 | 51/2 (140)   | 63/4 (171)   | 65/8 (168)    | 2.10              |
| 1702         | 3     | 75/16 (186)  | 8 (203)      | 8 (203)       | 2.95              |
| 1704         | 4 X 2 | 51/2 (140)   | 71/4 (184)   | 65/8 (168)    | 2.85              |
| 1706         | 4 X 3 | 71/4 (184)   | 81/2 (216)   | 8 (203)       | 3.90              |
| 1708         | 4     | 91/4 (235)   | 10 (254)     | 91/2 (241)    | 5.90              |
| 1714         | 5 X 4 | 93/4 (248)   | 101/2 (267)  | 113/16 (284)  | 7.55              |
| 1716         | 5     | 113/4 (298)  | 121/2 (318)  | 125/8 (321)   | 9.55              |
| 1718         | 6 X 2 | 81/4 (210)   | 85/16 (211)  | 1/2 (13)      | 4.95              |
| 1720         | 6 X 3 | 713/16 (198) | 91/2 (241)   | 93/4 (248)    | 5.65              |
| 1722         | 6 X 4 | 93/4 (248)   | 11 (279)     | 113/16 (284)  | 7.95              |
| 1726         | 6     | 135/8 (346)  | 143/8 (365)  | 141/16 (357)  | 13.55             |
| 1728         | 8 X 4 | 97/16 (240)  | 115/16 (287) | 113/16 (284)  | 11.30             |
| 1732         | 8 X 6 | 12 (305)     | 133/8 (340)  | 1315/16 (354) | 17.65             |

## SANITARY CROSS

(Corresponds to table 51 of CISPI 301)

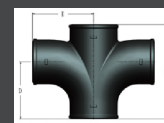

| ASA CODE NO. | SIZE  | D          | E ±1/8(3.2) | F ±1/8(3.2) | APPROX WTEA. [KG] |
|--------------|-------|------------|-------------|-------------|-------------------|
| 1858         | 4 X 2 | 41/2 (114) | 51/2 (140)  | 67/8 (175)  | 3.35              |
| 1862         | 4     | 51/2 (140) | 51/2 (140)  | 91/8 (232)  | 5.00              |

## SANITARY CROSS, TAPPED

(Corresponds to table 57 of CISPI 301)

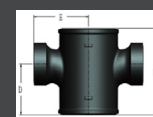

| ASA CODE NO. | SIZE     | D         | E ±1/8(3.2) | F ±1/8(3.2)  | APPROX WTEA. [KG] |
|--------------|----------|-----------|-------------|--------------|-------------------|
| 2016         | 2 X 11/2 | 31/4 (83) | 213/16 (71) | 511/16 (144) | 1.59              |
| 2018         | 2 X 2    | 33/4 (95) | 31/16 (78)  | 63/8 (162)   | 1.80              |
| 2022         | 3 X 11/2 | 31/4 (83) | 35/16 (84)  | 511/16 (144) | 2.25              |
| 2024         | 3 X 2    | 33/4 (95) | 39/16 (90)  | 63/8 (162)   | 2.49              |

## IRON BODY CLEANOUT - TAPPED

(Corresponds to table 67 of CISPI 301)



| ASA CODE NO. | SIZE | F          | APPROX WTEA. [KG] |
|--------------|------|------------|-------------------|
| 8566         | 4    | 23/16 (56) | 0.90              |

## SHORT, INCREASER - REDUCER (Corresponds to table 64 of CISPI 301)



| ASA CODE NO. | SIZE   | F±1/8(3.2)  | APPROX WTEA. (KG) |
|--------------|--------|-------------|-------------------|
| 2140         | 3 X 2  | 35/8 (92)   | 0.67              |
| 2142         | 4 X 2  | 35/8 (92)   | 1.05              |
| 2144         | 4 X 3  | 35/8 (92)   | 1.09              |
| 2146         | 5 X 2  | 4 (102)     | 1.25              |
| 2148         | 5 X 3  | 4 (102)     | 1.35              |
| 2150         | 5 X 4  | 4 (102)     | 1.45              |
| 2152         | 6 X 2  | 4 (102)     | 1.75              |
| 2154         | 6 X 3  | 4 (102)     | 1.82              |
| 2156         | 6 X 4  | 4 (102)     | 2.10              |
| 2158         | 6 X 5  | 4 1/2 (114) | 2.25              |
| 2160         | 8 X 2  | 4 1/2 (114) | 3.40              |
| 2162         | 8 X 3  | 4 1/2 (114) | 3.42              |
| 2164         | 8 X 4  | 4 1/2 (114) | 3.50              |
| 2166         | 8 X 5  | 5 (127)     | 3.55              |
| 2168         | 8 X 6  | 5 (127)     | 3.65              |
| 2172         | 10 X 4 | 5 1/2 (140) | 5                 |
| 2174         | 10 X 6 | 6 (152)     | 8                 |
| 2175         | 10 X 8 | 6 (152)     | 11                |

## BLIND PLUG (Corresponds to table 66 of CISPI 301)



| ASA CODE NO. | SIZE | F±1/8(3.2) | APPROX WTEA. (KG) |
|--------------|------|------------|-------------------|
| 2480         | 1.5  | 1 3/4 (44) | 0.30              |
| 2482         | 2    | 1 3/4 (44) | 0.30              |
| 2484         | 3    | 1 3/4 (44) | 0.50              |
| 2486         | 4    | 1 3/4 (44) | 0.90              |
| 2490         | 6    | 1 3/4 (44) | 1.82              |
| 2492         | 8    | 2 1/4 (57) | 3.5               |
| 2494         | 10   | 3 (76)     | 6                 |

## P-TRAP (Corresponds to table 68 of CISPI 301)

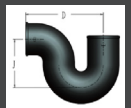

| ASA CODE NO. | SIZE | D ±1/8(3.2)  | J           | APPROX WTEA. (KG) |
|--------------|------|--------------|-------------|-------------------|
| 2506         | 1.5  | 6 3/4 (171)  | 3 1/2 (89)  | 1.5               |
| 2508         | 2    | 7 1/2 (191)  | 4 (102)     | 1.68              |
| 2510         | 3    | 9 (229)      | 5 1/2 (140) | 3.75              |
| 2512         | 4    | 10 1/2 (267) | 6 1/2 (165) | 6.25              |
| 2514         | 6    | 14 (356)     | 8 1/2 (216) | 19                |



# COUPLINGS ASTM C564/C1277



| SIZE    | QTY/CARTON | WEIGHT/CARTON (kg) |
|---------|------------|--------------------|
| 1 1/2 " | 100        | 13.0               |
| 2 "     | 100        | 13.4               |
| 3 "     | 100        | 16.2               |
| 4 "     | 100        | 21.4               |
| 5 "     | 50         | 21.5               |
| 6 "     | 50         | 24.8               |
| 8 "     | 30         | 22.2               |
| 10 "    | 25         | 24.0               |
| 12 "    | 16         | 25.5               |
| 15 "    | 10         | 20.0               |





# **PT. BRAVOINDO PERKASA JAYA**

Superblok MGK Kemayoran

Blok F no 9.

JL. Angkasa kav B6,

Jakarta 1060, Indonesia

P. +62 21 2937 1283 / 2937 1283

F. +62 21 2937 1428

E-mail : [sales@bravoindoperkasajaya.com](mailto:sales@bravoindoperkasajaya.com)